

## **USER'S MANUAL**

TIG/MMA dual function  
IGBT inverter technology  
AC/DC welding power source

**TIG 2800 DC**

## Introduction

First of all, thank you for choosing an IWELD welding or cutting machine!

Our mission is to support your work with the most up-to-date and reliable tools both for DIY and industrial application.

We develop and manufacture our tools and machines in this spirit.

All of our welding and cutting machines are based on advanced inverter technology, reducing the weight and dimensions of the main transformer.

Compared to traditional transformer welding machines the efficiency is increased by more than 30%.

As a result of the technology used and the use of quality parts, our welding and cutting machines are characterized by stable operation, impressive performance, energy efficient and environmentally friendly operation.

By activating the microprocessor control and welding support functions, it continuously helps maintain the optimum character of welding or cutting.

Read and use the manual instructions before using the machine please!

The user's manual describes the possible sources of danger during welding, includes technical parameters, functions, and provides support for handling and adjustment but keep in mind it doesn't contain the welding knowledge!

If the user's manual doesn't provide you with sufficient information, contact your distributor for more information!

In the event of any defect or other warranty event, please observe the „General Warranty Terms”.

The user manual and related documents are also available on our website at the product data sheet.

IWELD Kft.  
2314 Halásztelek  
II. Rákóczi Ferenc street 90/B  
Tel: +36 24 532 625  
info@iweld.hu  
www.iweld.hu

## WARNING!

Welding is a dangerous process! The operator and other persons in the working area must follow the safety instructions and are obliged to wear proper Personal Protection Items. Always follow the local safety regulations! Please read and understand this instruction manual carefully before the installation and operation!

- The switching of the machine under operation can damage the equipment.
- After welding always disconnect the electrode holder cable from the equipment.
- Always connect the machine to a protected and safe electric network!
- Welding tools and cables used with must be perfect.
- Operator must be qualified!

### **ELECTRIC SHOCK: may be fatal**

- Connect the earth cable according to standard regulation.
- Avoid bare hand contact with all live components of the welding circuit, electrodes and wires. It is necessary for the operator to wear dry welding gloves while he performs the welding tasks.
- The operator should keep the working piece insulated from himself/herself.

### **Smoke and gas generated while welding or cutting can be harmful to health.**

- Avoid breathing the welding smoke and gases!
- Always keep the working area good ventilated!

### **Arc light-emission is harmful to eyes and skin.**

- Wear proper welding helmet, anti-radiation glass and work clothes while the welding operation is performed!
- Measures also should be taken to protect others in the working area.

### **FIRE HAZARD**

- The welding spatter may cause fire, thus remove flammable materials from the working area.
- Have a fire extinguisher nearby in your reach!

### **Noise can be harmful for your hearing**

- Surface noise generated by welding can be disturbing and harmful. Protect your ears if needed!

### **Malfunctions**

- Check this manual first for FAQs.
- Contact your local dealer or supplier for further advice.

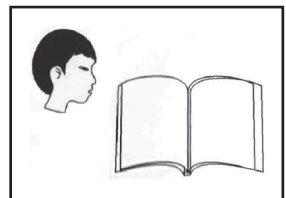
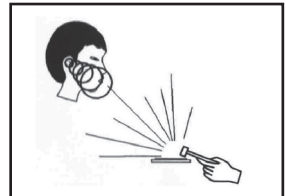
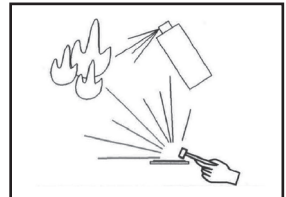
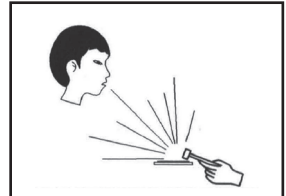
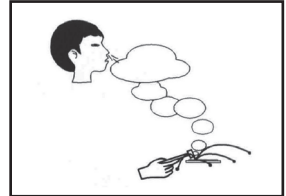
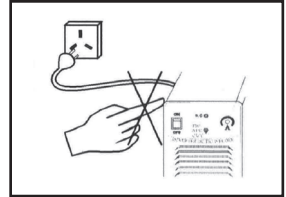

# PRECAUTIONS TO ELECTROMAGNETIC COMPATIBILITY

## 1 General

Welding may cause electromagnetic interference.

The interference emission of arc welding equipment can be minimized by adopting proper installation method and correct use method.

The products described in this manual belong to the limit of class A equipment (applies to all occasions except the residential areas powered by public low-voltage power system).

**Warning:** Class A equipment does not apply to the residential areas powered by public low-voltage power system. Because the electromagnetic compatibility cannot be guaranteed in these areas owing to conducted and radiated disturbances.

## 2 Environmental assessment suggestions

Before installing the arc welding equipment, user shall assess the potential electromagnetic disturbance problems in the surrounding environment. The following matters shall be considered:

- Whether there are other service cables, control cables, signal and telephone wires, etc. above, under or around the welding equipment;
- Whether there are radio and television transmitting and receiving devices;
- Whether there are computers and other control equipment;
- Whether there are high-security level equipment, such as industrial protective equipment;
- Consider the health of staff at the site, for example, where there are workers wearing hearing aid or pacemaker;
- Whether there are equipment used for calibration or inspection;
- Pay attention to the noise immunity of other equipment around. The user should ensure that the equipment is compatible with the surrounding equipment, which may require extra protective measures;
- Time for welding or other activities;

The range of environment shall be determined according to the building structure and other possible activities, which may exceed the boundary of building.

## 3 Methods to reduce emission

### - Public power supply system

The arc welding equipment shall be connected to the public power supply system according to the method recommended by the manufacturer. If there is interference, additional preventive measures shall be taken, such as access with filter in the public power supply system. For fixed arc welding equipment, the service cables shall be shielded by metal pipe or other equivalent methods. However, the shield shall ensure electrical continuity and shall be connected with the case of welding source to ensure the good electrical contact between them.

### - Maintenance of arc welding equipment

The arc welding equipment must be regularly maintained according to the method recommended by the manufacturer. When the welding equipment is running, all entrances, auxiliary doors and cover plates shall be closed and properly tightened. The arc welding equipment shall not be modified in any form, unless the change and adjustment are permitted in the manual. Particularly, the spark gap of arc striker and arc stabilizer shall be adjusted and maintained according to the manufacturer's suggestions.

### - Welding cable

The welding cable shall be as short as possible and close to each other and to the ground line.

### - Equipotential bonding

Pay attention to the bonding of all metal objects in surrounding environment. The overlapping of metal object and workpiece can increase the risk of work, as operators may suffer from electric shock when touch the metal object and electrode simultaneously. Operators shall be insulated from all these metal objects.

### - Grounding of the workpiece

For electrical safety or workpiece location, size and other reasons, the workpiece may not be grounded, such as the hull or structural steelwork. Grounding of workpieces sometimes can reduce the emission, but it is not always the case. So be sure to prevent the increasing risk of electric shock or damage of other electrical equipment caused by grounded workpieces. When necessary, the workpiece should be directly connected with the ground. But direct grounding is forbidden in some countries. In such case, use appropriate capacitor in accordance with regulations of the country.

### - Shielding

Selectively shield the surrounding equipment and other cables to reduce the electromagnetic interference. For special applications, the whole welding area can be shielded.

# The Main Parameters

QUICKSILVER		TIG 2800 DC	
Art. Nr.		800TIG2800DC	
FUNCTIONS	GENERAL	Inverter type	IGBT
		Water Cooling Unit	x
		Arc Ignition	HF/ LT
		Number of programs	10
		Wireless Remote Control	op.
		Remote Control from TIG Torch	✓
		LCD	✓
	TIG	AC TIG	x
		AC PULSE TIG	x
		DC TIG	✓
		DC PULSE TIG	✓
		2T/4T	✓
	Number of Waveforms	3	
	MMA	AC MMA	x
DC MMA		✓	
Adjustable Arc Force		✓	
Adjustable Hot Start		✓	
Accessories TIG Torch		IGrip SR26P (4m)	
Optional TIG Torch		-	
Phase number		3	
Rated input Voltage		3x400V AC ±10%, 50/60 Hz	
PARAMETERS	Max./eff. input Current	MMA	18A / 13.9A
		TIG	13.1A / 10.1A
	Power Factor (cos φ)		0.66
	Efficiency		85%
	<b>Duty Cycle (10 min/40 °C)</b>		<b>250A @ 60%</b> <b>195A @ 100%</b>
	Welding Current Range	MMA	5A - 250A
		TIG	5A - 250A
	Output Voltage	MMA	20.4V - 30V
		TIG	10.4V - 20V
	No-Load Voltage		TIG:58.2 / MMA:73,5V
Insulation		H	
Protection Class		IP21S	
Weight		17.1 kg	
Dimensions (LxWxH)		540x190x360 mm	

## 2. Installation instructions

### 2-1. Layout for Front and Rear panel

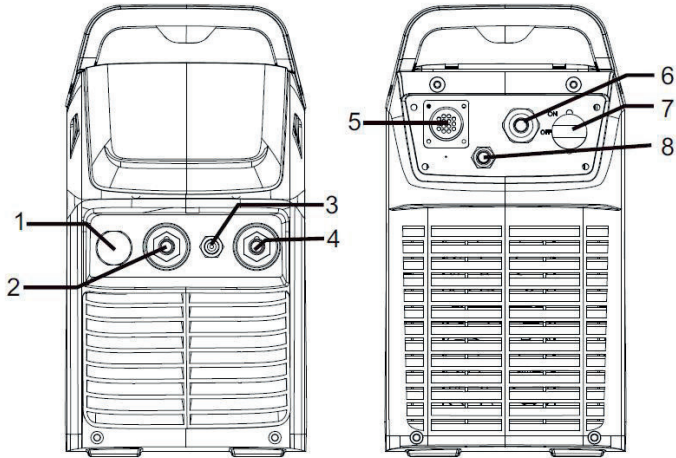

1	Aero socket: Is connected to torch switch control wire.
2	Negative output: The welder's negative polarity output.
3	Shield gas connector: Is connected to the gas input pipe of torch.
4	Positive output: The welder's positive polarity output.
5	Water box connector: Is connected to the water box.
6	Power source switch: Switch to "ON", the welder is turned on, while switch to "OFF", the welder is turned off.
7	Power source input: To connect power source.
8	Shield gas input joint: To connect one head of the gas hose while the other head is connected to argon gas cylinder.

### 3. Operation Instruction

#### 3-1. Control Panel

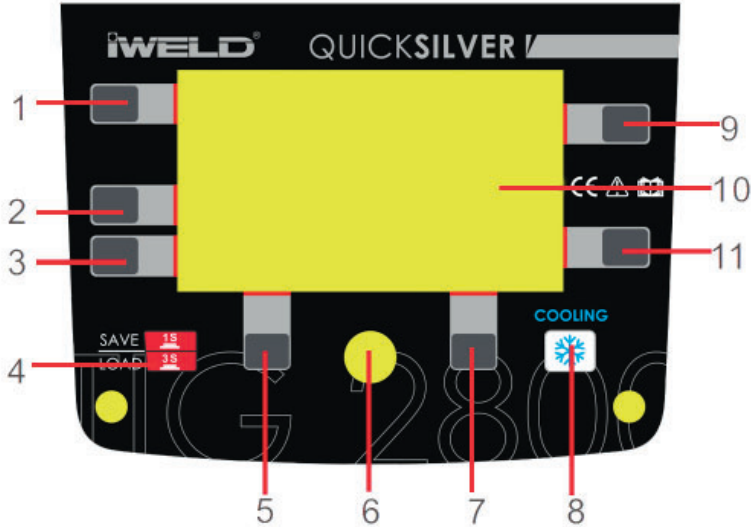

1.	Welding mode button: Press it to select MMA/ HF TIG/ Lift TIG welding mode.
2.	Trigger mode selecting button: Press it to select 2T or 4T trigger mode.
3.	Welding function button: Press it to select the opening or closing of Pulse mode and Spot welding mode.
4.	JOB button: Press it for 3s to open JOB program and press it for 1s to save parameters into JOB number.
5.	Function A button.*
6.	Parameters select/adjust knob.*
7.	Function B button.*
8.	Cooling mode selecting button: Press it to select Air cooling or Water cooling.
9.	Hot Start button: Press it to select Hot start. If the button is not pressed within 3s, the selection will be automatically removed. Setting range: 0~10.
10.	Screen: It will show all welding parameters, such as welding voltage, welding current and other parameters set.
11.	Arc Force button: Press it to select Arc Force. If the key is not pressed within 3s, the selection will be automatically removed. Setting range: 0~10.

## **Further Controls Explained**

### **Function A button (5)**

In HF TIG/ Lift TIG, press it to select Pre-gas time, Pre-current and Up-slope time; In Spot welding mode, press it to select Pre-gas time; In JOB program, press it to load the parameter settings for the select number.

### **Function B button (7)**

In HF TIG/ Lift TIG, press it to select Down slope time, Post current and Post-gas time; In Spot welding mode, press it to select Post-gas time; In JOB program, press it to delete the parameter settings for the select number.

### **Parameters select/adjust knob (6)**

Press it to select parameters, such as welding current, Peak current, Base current, Pulse frequency, Pulse width and the JOB program number. Rotate it to adjust parameters' value.



## 3.2 MMA display introduction

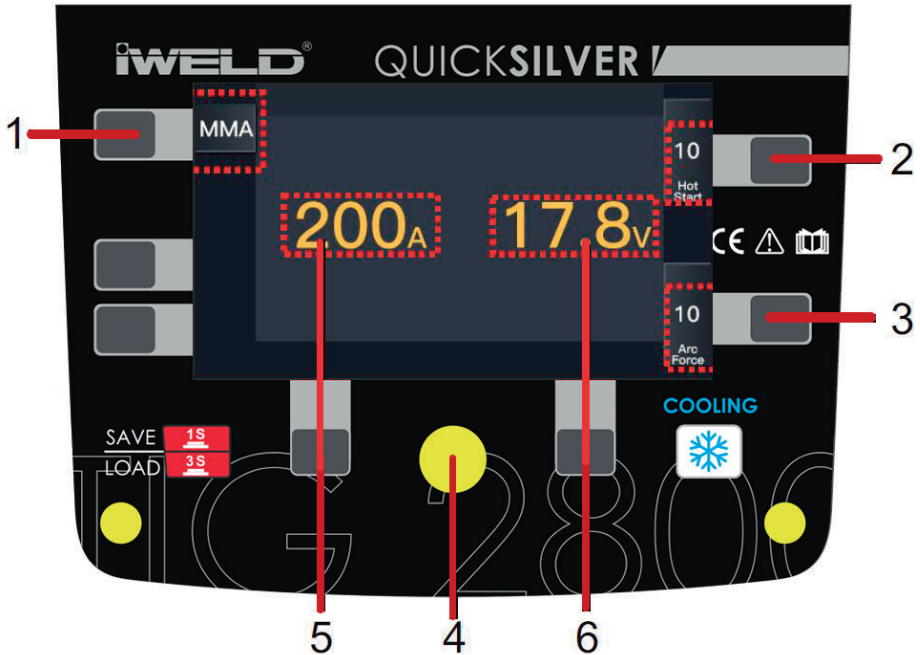

1.	Welding mode button: Press it to enter MMA welding mode.
2.	Hot Start button: Press it to select Hot start.
3.	Arc Force button: Press it to select Arc force.
4.	Parameter adjust knob: Rotate it to adjust welding current and value of Hot start and Arc force.
5.	Current display: It displays welding current during welding operation, otherwise show current selected.
6.	Welding voltage display: It displays welding voltage.

### 3.3 HF/LIFT TIG display introduction

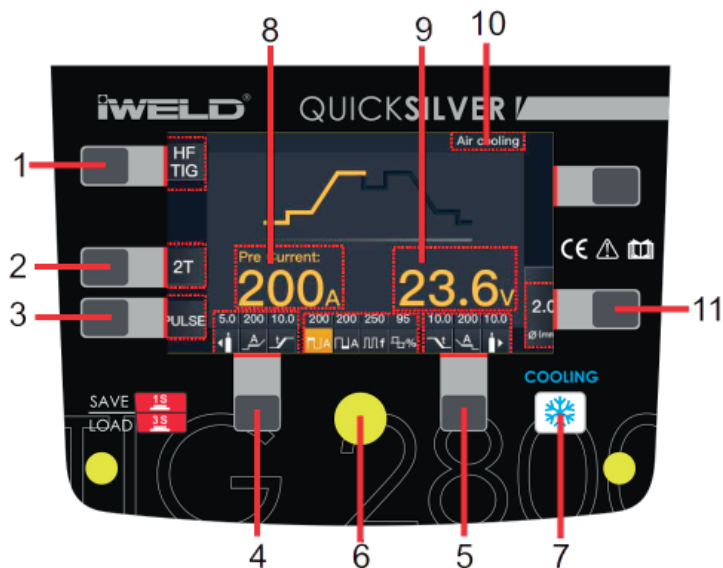

1.	Welding mode button: Press it to enter HF TIG or Lift TIG welding mode.
2.	Trigger mode button: Press it to select 2T or 4T trigger mode. *
3.	Welding function button: Press it to select No Pulse/ Pulse/ Spot welding function. (Here is no Spot function in Lift TIG welding mode.)
4.	Function A button: Press it to select Pre-gas time, Start arc current, Up slope time.
5.	Function B button: Press it to select Down slope time, End arc current and Post-gas time.
6.	Parameters select/adjust knob: Press it to select welding current and other parameters. Rotate it to adjust parameters' value.
7.	Cooling mode selecting button: Press it to select water cooling.
8.	Current display: It displays welding current during welding operation, otherwise show current selected.
9.	Welding voltage display.
10.	Cooling mode display.
11.	Diameter button: Press it to select diameter size.

### 3.4 TIG pulse display introduction

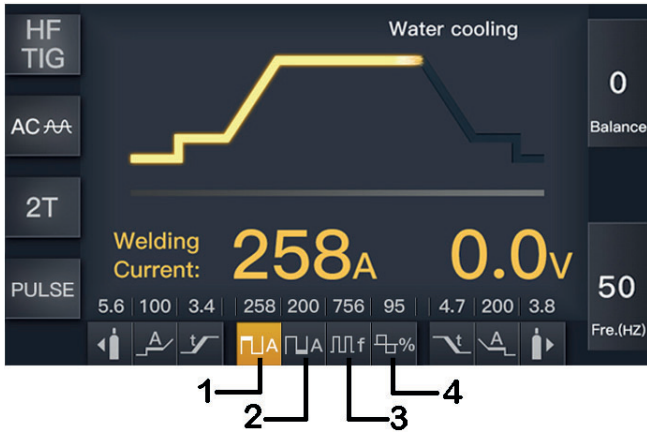

1.	<b>Peak current</b>	It is 5% to 100% of the main welding current.
2.	<b>Base current</b>	It is 5% to 100% of the main welding current, but less than Peak current.
3.	<b>Pulse frequency</b>	0.5~999Hz.
4.	<b>Pulse width</b>	5~95%.

### 3.5 TIG spot display introduction

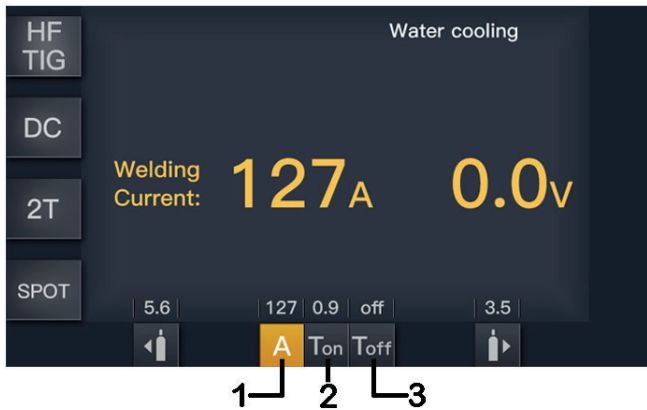

1.	<b>Current display</b>	10~320A.
2.	<b>T<sub>on</sub> display</b>	0.1~1.0s.
3.	<b>T<sub>off</sub> display</b>	off~10.0s.

### 3.6 JOB Program introduction

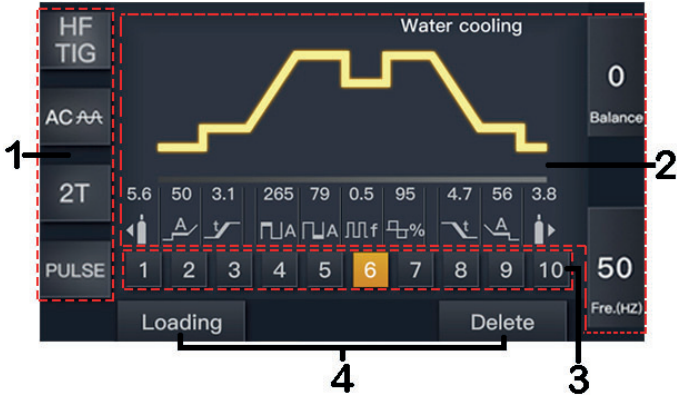

1.	<b>Welding mode display</b>	Here are selected welding states.
2.	<b>Parameters display</b>	Here are all selected parameters values.
3.	<b>JOB number</b>	A total 1~10 JOB numbers can store or call the selected parameters by JOB button.
4.	<b>Load/ Delete display</b>	Press Function A/B button to call/delete parameters setting for the selected JOB number.

## 2T operation:

This function without the adjustment of start current and crater current is suitable for the Re-tack welding, transient welding, thin plate welding and so on.

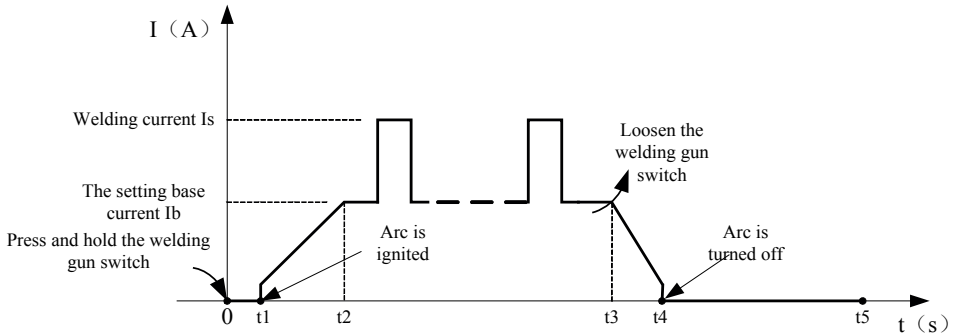

- 0: Press the gun switch and hold it. Electromagnetic gas valve is turned on. The shielding gas starts to flow.
- 0~ $t_1$ : Pre-gas time (0.0-2 sec)
- $t_1$ ~ $t_2$ : Arc is ignited ( $t_1$ ) and the output current rises ( $t_2$ ) to the setting welding current ( $I_w$  or  $I_b$ ) from the min welding current. (0.0-10 sec)
- $t_2$ ~ $t_3$ : During the whole welding process, the gun switch is pressed and held without releasing.

**Note:** Select the pulsed output, the base current and welding current will be outputted alternately; otherwise, output the setting value of welding current;

- $t_3$ : Release the gun switch, the welding current will drop in accordance with the selected down-slope time.
- $t_3$ ~ $t_4$ : The current drops to the minimum welding current from the setting current ( $I_w$  or  $I_b$ ), and then arc is turned off. (0.0-10 sec)
- $t_4$ ~ $t_5$ : Post-gas time, after the arc is turned off. You can adjust it through turning the knob on the front panel. (0.0-10 sec)
- $t_5$ : electromagnetic gas valve turned off, the shield gas stops to flow, and welding is finished.

## 4T operation:

The start current and crater current can be pre-set. This function can compensate the possible crater that appears at the beginning and end of the welding. Thus, 4T is suitable for the welding of medium thickness plates.

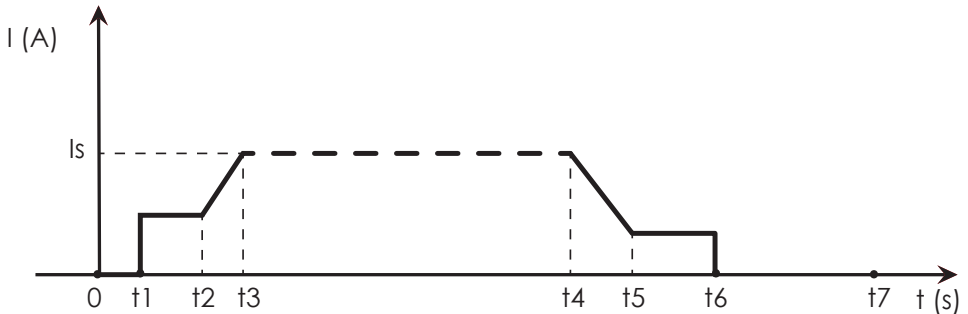

- 0: Press and hold the gun switch, Electromagnetic gas valve is turned on. The shielding gas starts to flow;
- 0~ $t_1$ : Pre-gas time (0.1~1S);
- $t_1$ ~ $t_2$ : Arc is ignited at  $t_1$  and then output the setting value of start current; (DC:10-170A; AC:10-200A)
- $t_2$ : Loosen the gun switch, the output current slopes up from the start current; (0.0-10sec)
- $t_2$ ~ $t_3$ : The output current rises to the setting value ( $I_w$  or  $I_b$ ), the upslope time can be adjusted; (DC:10-170A; AC:10-200A)
- $t_3$ ~ $t_4$ : Welding process. During this period, the gun switch is loosen;

**Note:** Select the pulsed output, the base current and welding current will be outputted alternately; otherwise, output the setting value of welding current;

- $t_4$ : Press the torch switch again, the welding current (DC:10-170A; AC:10-200A) will drop in accordance with the selected down-slope time. (0.0-10sec)
- $t_4$ ~ $t_5$ : The output current slopes down to the crater current. The downslope time can be adjusted;
- $t_5$ ~ $t_6$ : The crater current time;
- $t_6$ : Loosen the gun switch, stop arc and keep on argon flowing;
- $t_6$ ~ $t_7$ : Post-gas time can be set by the post-gas time adjustment knob on the front panel (0.0-10sec);
- $t_7$ : Electromagnetic valve is closed and stop argon flowing. Welding is finished.

### 3.7. Welding parameters setting

Welding mode	Trigger mode	Pre-gas time	Pre current	Up slope time	Peak current	Base current	Pulse frequency	Pulse width	Down slope time	Post current	Post-gas time	Spot time	Arc force	Hot-start
MMA	NO	x	x	x	10-max	x	x	x	x	x	x	x	0-10	0-10
DC TIG	2T	0.1-2s	10-max	0-10s	10-max	x	x	x	0-10s	10-P_C	0-10s	x	x	x
	4T	0.1-2s	10-max	0-10s	10-max	x	x	x	0-10s	10-P_C	0-10s	x	x	x
	Spot welding	0.1-2s	x	x	10-max	x	x	x	x	x	0-10s	On: 0.1-1s, Off: 0-10s	x	x
DC Pulse TIG	2T	0.1-2s	10-max	0-10s	10-max	10-max	0.5-999Hz	5-95%	0-10s	10-P_C	0-10s	x	x	x
	4T	0.1-2s	10-max	0-10s	10-max	10-max	0.5-999Hz	5-95%	0-10s	10-P_C	0-10s	x	x	x
	Spot welding	0.1-2s	x	x	10-max	x	x	x	x	x	x	On: 0.1-1s, Off: 0-10s	x	x
AC TIG	2T	0.1-2s	10-max	0-10s	10-max	x	x	x	0-10s	10-P_C	0-10s	x	x	x
	4T	0.1-2s	10-max	0-10s	10-max	x	x	x	0-10s	10-P_C	0-10s	x	x	x
AC Pulse TIG	2T	0.1-2s	10-max	0-10s	10-max	10-max	0.5-999Hz	5-95%	0-10s	10-P_C	0-10s	x	x	x
	4T	0.1-2s	10-max	0-10s	10-max	10-max	0.5-999Hz	5-95%	0-10s	10-P_C	0-10s	x	x	x

## 4. Installation & Operation for MMA welding

### 4.1 Set up and installation for MMA Welding

#### Connection of Output Cables

Two sockets are available on this welding machine. For MMA welding the electrode holder is shown be connected to the positive socket, while the earth lead (work piece) is connected to the negative socket, this is known as DCEP. However various electrodes require a different polarity for optimum results and careful attention should be paid to the polarity, refer to the electrode manufacturer's information for the correct polarity.

**DCEP:** Electrode connected to "+" output socket.

**DCEN:** Electrode connected to "-" output socket.

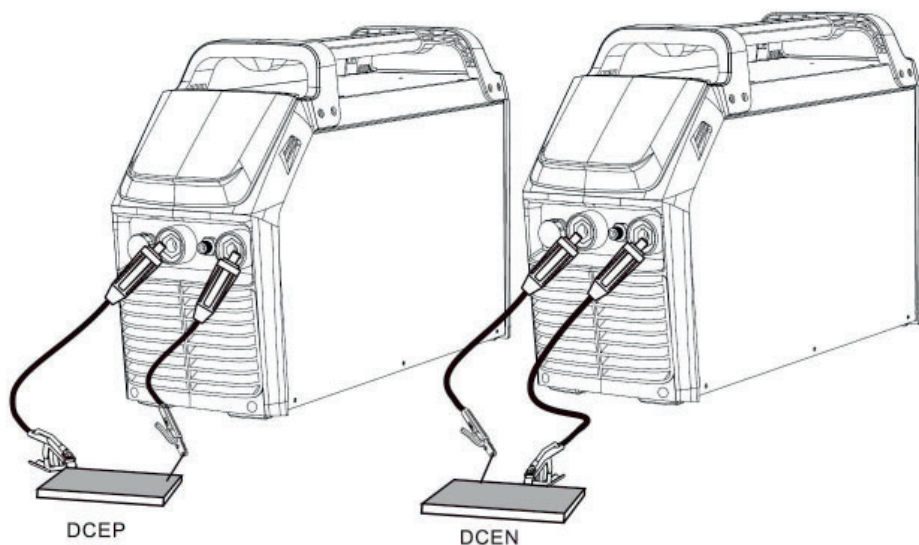

- (1) Connect the earth lead to "-", tighten clockwise;
- (2) Connect the earth clamp to the work piece. Contact with the work piece must be firm contact with clean, bare metal, with no corrosion, paint or scale at the contact point.
- (3) Connect the electrode lead to "+", tighten clockwise;
- (4) Each machine is equipped with a power cable should be based on the input voltage welding cable connected to the appropriate position, not to pick the wrong voltage;
- (5) With the corresponding input power supply terminal or socket good contact and prevent oxidation;
- (6) With a multimeter measure the input voltage is within the fluctuation range;
- (7) The power ground is well grounded.



## 4.2. Operation for MMA Welding

- (1) According to the above method to install is correct, rotate the power switch, so that the power switch is "ON" position, then the screen light and the fan comes on, the device work properly.
- (2) Set to 'MMA' welding mode.
- (3) Set welding current as required using the parameter knob.
- (4) Set the hot start and arc force as required using the parameter buttons and knob. (following the instructions in the previous section)
- (5) Place the electrode into the electrode holder and clamp tight.
- (6) Strike the electrode against the work piece to create an arc and hold the electrode steady to maintain the arc.
- (7) Commence welding. If necessary, readjust the Welding parameters control knob to obtain the welding condition required.
- (8) After completion of welding the Power Source should be left turned ON for 2 to 3 minutes. This allows the fan to run and cool the internal components.
- (9) Rotate the power switch to the OFF position.

### NOTE:

- Note the polarity of wiring, the general DC welding wire in two ways. Selected according to the technical requirements of welding the appropriate connection, if you choose incorrectly will result in arc instability and spatter large adhesion and other phenomena, such cases can be quickly reversed to joints.
- If the work piece distance from the welding machine, the second line (electrode holder and ground) is longer, so choose the appropriate conductor cross-sectional area should be larger to reduce cable voltage drop.

## 5. Installation & Operation for TIG welding

### 5.1. Set up and installation for TIG Welding

- (1) Insert the earth cable plug into the positive socket on the front of the machine and tighten it.
- (2) Plug the welding torch into the negative socket on the front panel, and tighten it.
- (3) Connect the gas line of TIG Gun to outlet gas connector on the front of the machine.
- (4) Connect the control cable of torch switch to 12 pin socket on the front of the machine.
- (5) Connect the water inlet and outlet pipe of TIG Gun to inlet and outlet water connector on the front of the water box.
- (6) Connect the control cable of water box with the aero socket on the rear panel of welding machine.
- (7) Connect the gas regulator to the Gas Cylinder and connect the gas line to the Gas Regulator. Check for Leaks!
- (8) Connect the gas line to the machine inlet gas connector via the quick push lock connector located on the rear panel. Check for Leaks!

NOTE: Air cooling mode without cooling device □ and the water pipe is not needed for the air cooling mode.

- (9) Connect the power cable of welding machine with the output switch in electric box on site. Turn on the power switch.
- (10) Carefully open the valve of the gas cylinder, set the required gas flow rate.
- (11) Select "Lift TIG" or "HF TIG" on the front panel.
- (12) Set torch operation 2T/4T.
  - When 2T operation is selected, press trigger Gas starts, touch and lift arc start. Release trigger Gas and Arc stops.
  - When 4T operation is selected, press and release trigger Gas starts, touch and lift arc start. Press and release trigger again, Gas and Arc stops.
- (13) Set welding function NO PULSE/PULSE/SINGLE SPOT/MULTI SPOT.
- (14) Set current and TIG parameter setting, including Pre Gas, Slow down, etc.
- (15) Select cooling mode gas/water on the front panel.

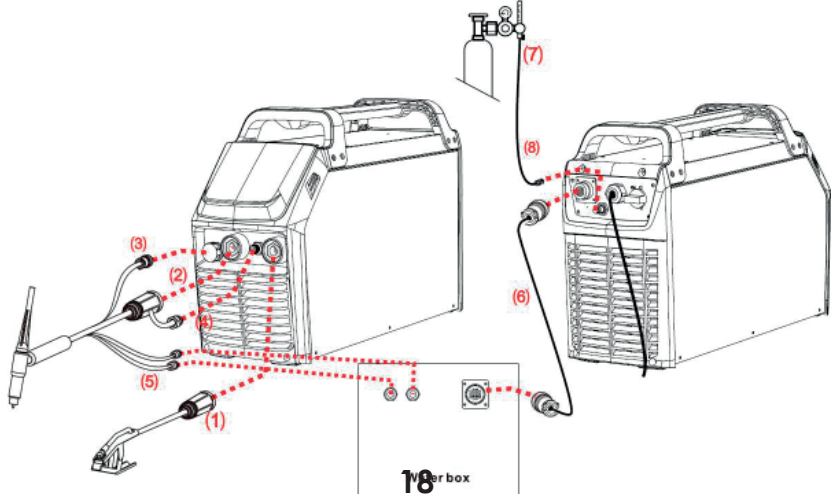

## 5.2. Operation for TIG Welding

- (1) According to the above method to install is correct, turn the power switch to the "ON" position, the screen should illuminate, the fan comes on, the device work properly.
- (2) Set the welding mode to 'Lift TIG' or 'HF TIG' and the output waveform: DC or AC.
- (3) Set trigger mode: 2T/4T.
  - When 2T operation is selected, press trigger Gas starts, touch and lift arc start. Release trigger Gas and Arc stops.
  - When 4T operation is selected, press and release trigger Gas starts, touch and lift arc start. Press and release trigger again, Gas and Arc stops.
- (4) Set up current and TIG parameter setting, including Pre Gas, Slow down, etc.
- (5) Select water cooling mode on the front panel.
- (6) The tungsten must be ground to a blunt point in order to achieve optimum welding results. It is critical to grind the tungsten electrode in the direction the grinding wheel is turning.
- (7) Install the tungsten with approximately 3-7 mm sticking out from the gas cup, ensuring you have correct sized collet.
- (8) Tighten the back cap.
- (9) Commence welding. If necessary, readjust the parameters control knob to obtain the welding condition required.
- (10) After completion of welding the Power Source should be left turned ON for 2 to 3 minutes. This allows the fan to run and cool the internal components.
- (11) Switch the ON/OFF Switch to the OFF.

## Duty Cycle Curve

The letter "X" stands for duty cycle, which is defined as the proportion of the time that a machine can work continuously within a certain time (10 minutes). The rated duty cycle means the proportion of the time that a machine can work continuously within 10 minutes when it outputs the rated welding current. The relation between the duty cycle "X" and the output welding current "I" is shown as the right figure.

If the welder is over-heat, the IGBT over-heat protection unit inside it will output an instruction to cut output welding current, and brighten the over-heat pilot lamp on the front panel. At this time, the machine should be relaxed for 15 minutes to cool the fan. When operating the machine again, the welding output current or the duty cycle should be reduced.

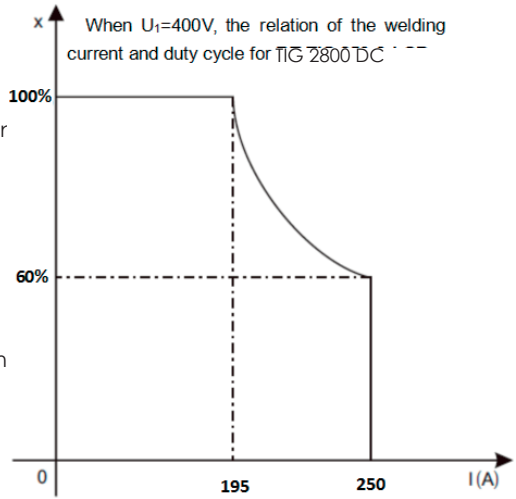

**Warning: Work in Overload is Harmful to the Welding Machine**

## Volt-Ampere Characteristic

TIG 2800 DC welding machine has an excellent volt-ampere characteristic, whose graph is shown as the following figure.

The relation between the conventional rated loading voltage  $U_2$  and the conventional welding current  $I_2$  is as follows:

When  $I_2 \leq 600A, U_2 = 10 + 0.04I_2 (V)$ ; When  $I_2 \geq 600A, U_2 = 34 (V)$ .

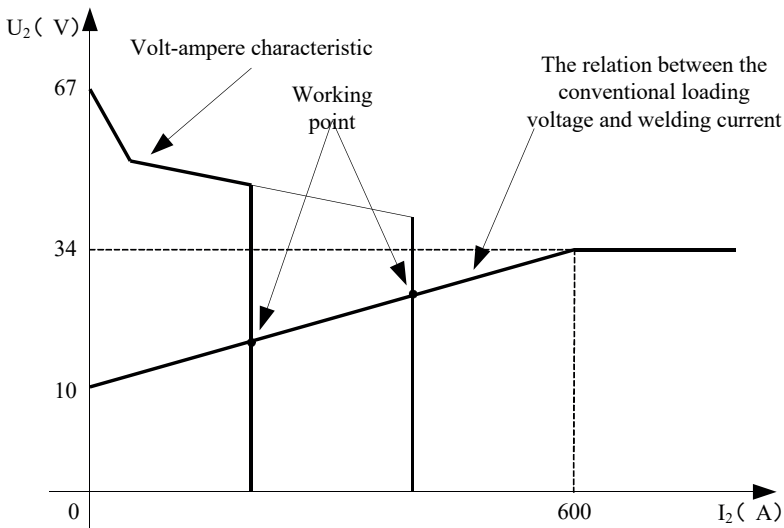

# Precautions

## Workspace

1. Welding equipment free of dust, corrosive gas, non-flammable materials, up to 90% humidity for use!
2. Avoid welding outdoors unless protected from direct sunlight, rain, snow, work area temperature must be between -10 °C and +40°C.
3. Wall to position the device at least 30 inches away.
4. Well-ventilated area to perform welding.

## Safety requirements

Welding provides protection against overvoltage / overcurrent / overheating. If any of the above events occurs, the machine stops automatically. However, over-stress damage to the machine, keep the following guidelines:

1. Ventilation. When welding a strong current going through the machine, so the machine is not enough natural ventilation for cooling. The need to ensure adequate cooling, so the distance between the plane and any object around it at least 30 cm. Good ventilation is important to normal function and service life of the machine.
2. Continuously, the welding current does not exceed the maximum allowable value. Current overload may shorten its life or damage to the machine.
3. Surge banned! Observance of tension range follow the main parameter table. Welding machine automatically compensates for voltage, allowing the voltage within permissible limits of law. If input voltages exceed the specified value, damaged parts of the machine.
4. The machine must be grounded! If you are operating in a standard, grounded AC pipeline in the event of grounding is provided automatically. If you have a generator or foreign, unfamiliar, non-grounded power supply using the machine, the machine is required for grounding connection point earth to protect against electric shock.
5. Suddenly stopping may be during welding when an overload occurs or the machine overheats. In this case, do not restart the computer, do not try to work with it right away, but do not turn off the power switch, so you can leave in accordance with the built-in fan to cool the welding machines.

## WARNING!

If the welding equipment is used with the welding parameters above 180 amperes, the standard 230V electrical socket and plug for 16 amp circuit breaker is not sufficient for the required current consumption, it is necessary to use the welding equipment with 20A, 25A or even to the 32A industrial fuses! In this case, both the plug and the plug socket fork have to be replaced to 32A single phase fuse socket in compliance with all applicable rules. This work may only be carried out by specialists!

## Maintenance

1. Remove power unit before maintenance or repair!
2. Ensure that proper grounding!
3. Make sure that the internal gas and electricity connections are perfect and tighten, adjust if necessary, if there is oxidation, remove it with sandpaper and then reconnect the cable.
4. Hands, hair, loose clothing should be kept away under electric parts, such as wires, fan.
5. Regularly dust from the machine clean, dry compressed air, a lot of smoke and polluted air to clean the machine every day!
6. The gas pressure is correct not to damage components of the machine.
7. If water would be, for example. rain, dry it in the machine and check the insulation properly! Only if everything is all right, go after the welding!
- 8 When not in use for a long time, in the original packaging in a dry place.

**CERTIFICATE OF EUROPEAN STANDARD**

Manufacturer: IWELD Ltd.  
2314 Halásztelek  
II. Rákóczi Ferenc street 90/B  
Tel: +36 24 532-625  
info@iweld.hu  
www.iweld.hu

Item: **TIG 2800** DC TIG/MMA dual function IGBT inverter  
technology DC welding power source

Applied Rules (1): EN 60204-1:2005  
EN 60974-10:2014,  
EN 60974-1:2018

(1) References to laws, rules and regulations are to be understood as related to laws, rules and regulations in force at present.  
Manufacturer declares that the above specified product is complying with all of the above specified rules and it also complying with the essential requirements as specified by the Directives 2014/35/EU, 2014/30/EU, 2006/42/EU and 2011/65/EU

Serial No.:



Halásztelek (Hungary),

14/03/21

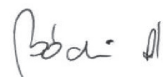
Managing Director:  
András Bódi